

LYNX Touch Series Control

Quick Installation Guide

This Quick Installation Guide can help you install the rechargeable LYNX Touch Series Control quickly and easily by providing the basic steps for installation using the built-in defaults.

FOR DOCUMENTATION AND ONLINE SUPPORT: <http://www.security.honeywell.com/hsc/resources/MyWebTech> (see LYNX Touch Series Installation and Setup Guide P/N 800-06834 or higher.) A copy of the Installation and setup Guide may also be requested from Honeywell.

WARRANTY INFORMATION

For the latest warranty information, please go to:
www.honeywell.com/security/hsc/resources/wa

1. Install the Control

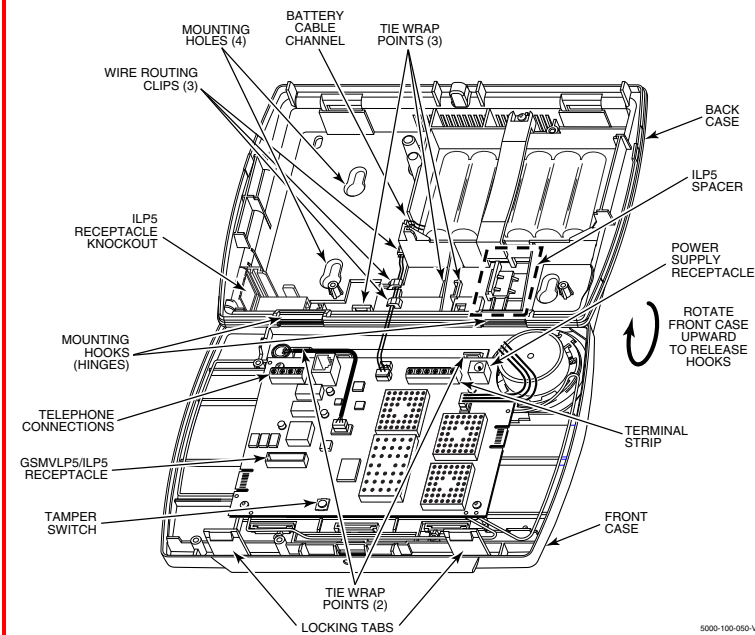

1. Release the front case from the rear case by depressing the two locking tabs at the top of the unit with the blade of a medium size screwdriver.
2. Separate the front and back case assemblies by rotating the front case so that it is perpendicular to the rear case and unsnapping (releasing) the two hooks (hinges) from the back case.
3. Feed the wiring through the appropriate openings in the back case. Use tie wraps to secure the wiring to the built-in wire loops as needed.
4. Mount the back case to a sturdy wall and secure with the provided screws.
5. Attach the front and back cases by connecting the hooks on the front case to the attachments on back case. Once attached, the hooks will support the front case and allow you to make the wiring connections.
6. After all of the wiring connections have been made, snap the front case and back case closed and ensure that the locking tabs secure the case.

2. Make Wiring Connections

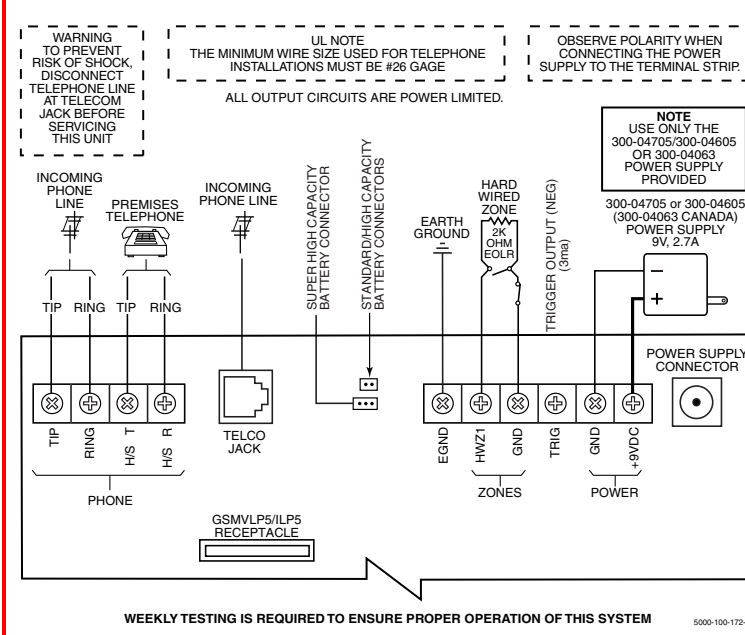

- Note:** For the complete Summary of Connections, refer to the LYNX Touch Series Installation and Setup Guide P/N 800-06834 or higher.
1. Make earth ground connections to EGND terminal.
 2. Connect the incoming phone line to either the 8-position jack or the TIP and RING terminals.
 3. Connect the handset phone lines to the H/S T (TIP) and H/S R (RING) terminals.
 - Note:** For full line seize operation, refer to the LYNX Touch Series Installation and Setup Guide.
 4. Connect the sensors/contacts to the HWZ1 (+) and GND (-) terminals.
 5. If used, install the GSMVLP5 or ILP5 communications module. Refer to the Install the Communications Module section or to the Installation Guide for the Communications Module (P/N 800-01115 or higher).
 6. Connect wires from the 300-04705/300-04605 OR 300-04063 (Canada) Power Supply to GND (-) and +9VDC (+) terminals OR plug the Power Supply connector into the receptacle on the LYNX Touch.

3. Install the Communications Module

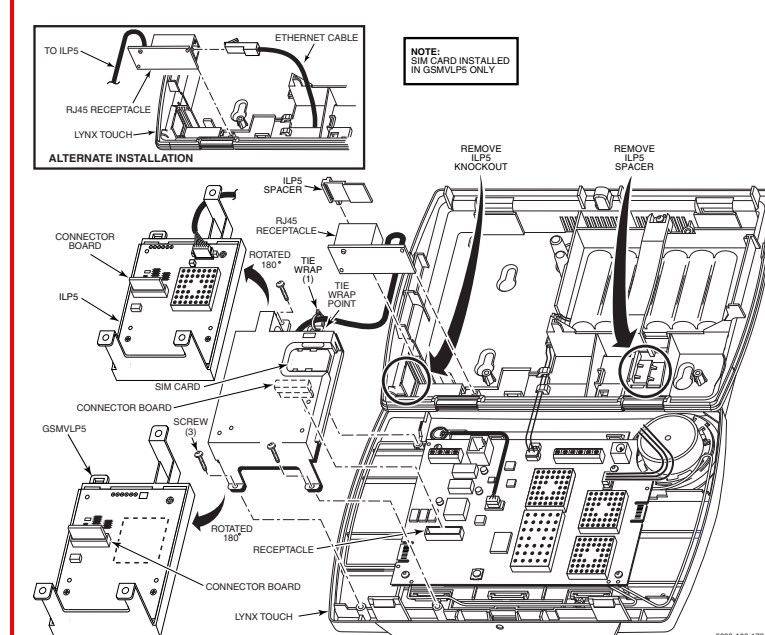

- Ensure that SIM card and the connector board are securely installed in the communications module before installing it in the LYNX Touch.**
1. If you are installing the ILP5 module, use a wire cutter or knife to cut the plastic tabs that secure the ILP5 spacer to the back case of the LYNX Touch. If you are installing the GSMVLP5 module, proceed to step 3.
 2. Remove the ILP5 receptacle knockout from the left side of the LYNX Touch back case.
 3. Install the Communications Module into the front case. Ensure that the connector board is properly seated into the receptacle on the control.
 4. Secure the module with the three provided screws. If you are installing the ILP5 module, proceed to step 5. If you are installing the GSMVLP5 module, proceed to step 8.
 5. Insert the ILP5 receptacle and spacer into the slot on the back case.
 6. Secure the communications cable to the tie wrap point on the ILP5 with the provided tie wrap.
 7. Connect the Ethernet cable to the RJ45 receptacle.
 8. Enable the module, configure alarm reporting and module supervision and register the device. Refer to the "Program the Radio" and "Diagnostics" sections of the LYNX Touch Installation Guide (P/N 800-06834 or higher).

4. Make Battery Connections

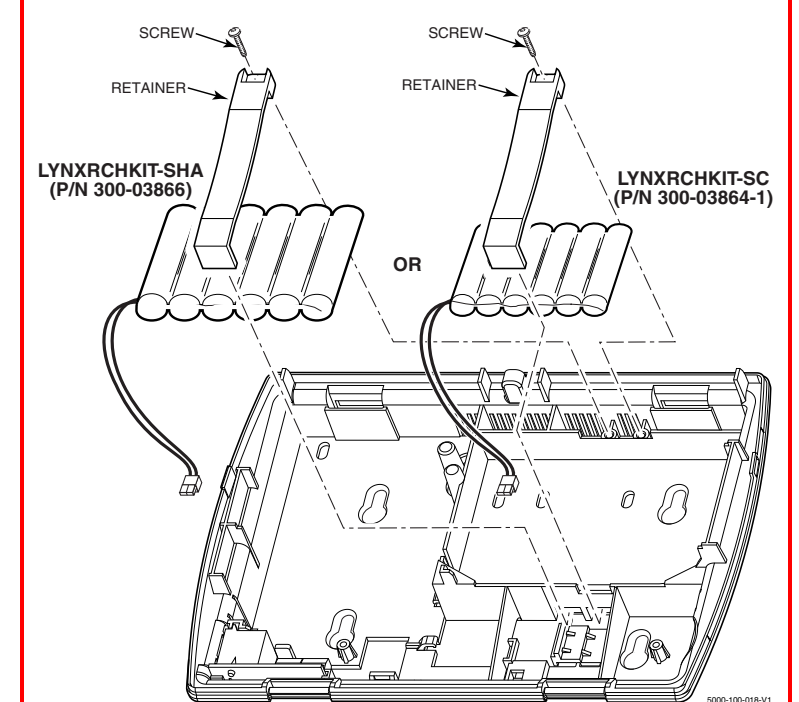

1. Remove screw securing the battery retainer.
 2. Remove the battery retainer.
 3. Insert battery pack into back case.
 4. Install battery retainer.
 5. Install screw to secure the battery retainer.
 6. Connect battery connector to receptacle on PC board.
 7. After all wiring connections have been made, snap the front case to the back case so it is held by the locking tabs.
 8. Plug the Power Supply into a 24-hour, 110VAC unswitched outlet.
- Note:** Rechargeable batteries may take up to 48-hours to fully charge. "Battery Low" message should clear within four hours, or by entering Test Mode.

Battery Part Number	Battery Standby Time (Minimum)	Low Battery Notification
LYNXRCHKIT-SC (300-03864-1)	4-hours	Approx. 1-hour before battery depletion
LYNXRCHKIT-SHA (300-03866)	24-hours	At least 1-hour before battery depletion



800-06896 3/11 Rev. A

Honeywell

2 Corporate Center Drive, Suite 100
P.O. Box 9040, Melville, NY 11747
Copyright © 2011 Honeywell International Inc.
www.honeywell.com/security

Programming Notes

Entering Installer Programming mode

1. Power-up the control and select the "more" tab on the first page of the Home Screen.
2. Select "Tools" button.
3. Enter the 4-digit Installer Code (4-1-1-2).
4. Select "Program" button.
5. The System Programming Screen will appear and the "ARMED" and "READY" LEDs will flash.

Exiting Programming mode

1. Once programming is completed, at the System Programming screen, select the "⏪" button.
2. Select the "Yes" when the system prompts "Allow Installer to Re-Enter Programming?".
3. Select the "⏪" button to return to the Home Screen.

Entering Master User Programming mode

1. Power-up the control and select the "more" tab on the first page of the Home Screen.
2. Select "Tools" button.
3. Enter the 4-digit Master User Code (1-2-3-4).
4. The Master User Programming Screen will appear and the "READY" LED will remain lit.
5. Select the applicable programming function from the Master User screen.

Exiting Programming mode

1. Once programming is completed, select the "back" tab to return to the Home Screen.

OR

2. Depress the "Off" key and then select the "Cancel" button.
3. The system will return to the Home Screen.

5. Program the Control

Change the Installer Code

The factory default Installer Code for the LYNX Touch Series Control is set to 4-1-1-2. To change this code, you must enter Programming mode.

1. Select "Program" button.
2. Select "Installer Code" button.
3. Enter a new 4-digit Installer Code.
4. Select "Done" button

Program Date

Note: If you are installing a GSMVLP5 or ILP5 Communication Module, the time and date will be programmed and updated automatically via Central Station. You must still program the correct Time Zone

To change this code, you must enter Programming mode.

1. Select "Program" button.
2. Select "Date Time" button.
3. Enter the date, time and time zone as required.
4. Select "Save" button.

Program Defaults

LYNX Touch is pre-programmed at the factory with a built-in set of default values. Refer to the Programming Default Tables section of the LYNX Touch Series Installation and Setup Guide (P/N 800-06834 or higher) to view the Default Tables. To select factory defaults from a set of four tables, you must enter Programming mode.

1. Select "Program" button.
2. Select "Default Config." button.
3. Select the desired Default Table.
4. Select "Yes" when the confirmation screen appears.

6. Add Wireless Sensors

Add a Sensor

To add, edit or delete Wireless Sensors you must enter Programming Mode.

1. Select "Zones" button.
2. Select "Add new" button.
3. Select the applicable Zone button.
4. Select "Serial Number" Button
5. Enter Serial Number or **Enroll via RF Learning**. To enroll the transmitter, three (open/close) transmissions of the device will be required.
6. If desired, program the following options:
Loop Number
Zone Description 1 and 2
Device Type
Response Type
Alarm Report
Chime
Supervision
7. Select "Save".

Edit Wireless Sensor/Zone information

1. Select "Zones" button.
2. Select the Zone you wish to edit and then select the "Edit" button.
3. Edit the applicable zone programming fields as required.
4. Select "Save".

Delete a Wireless Sensor

1. Select "Zones" button.
2. Select the Zone you wish to delete then select the "Delete" button.
3. Select the "Yes" button when the confirmation screen appears.

6. Add Wireless Keys

To add, edit or delete a Wireless Key you must enter Programming Mode.

Add a Wireless Key

1. Select "Keys" button.
2. Select "Add New" button.
3. Select the "Key Type" button and scroll through the available key types.
4. Select "Serial Number" Button
5. Enter Serial Number or **Enroll via RF Learning**. To enroll the transmitter, three (open/close) transmissions of the device will be required.
6. Select the "User" button and then select the User that will be associated with the key that is being enrolled.

Note: In order for the Key to function, a valid User Code must be associated with the User that has been assigned to the key.

7. If desired, program the following options:

Zone
Button Key * - Zn **

8. Select "Save".

* Button number is determined by the type of key being enrolled.
** Zn No. based on the type of key being enrolled.

Edit Wireless Key information

1. Select "Keys" button.
2. Select the Key you wish to edit and then select the "Edit" button.
3. Edit the applicable fields as required
4. Select "Save".

Delete a Wireless Key

1. Select "Keys" button.
2. Select the Key you wish to delete then select the "Delete" button.
3. Select the "Yes" button when the confirmation screen appears.

7. Add Central Station Accounts

To add Central Station Account information, you must enter Programming Mode.

Add First or Second Central Station Information

1. Select the "Reporter" button.
2. Select the "Primary Central Station" or "Secondary Central Station" button.
3. Program the following fields as applicable:
Phone Type
Phone Number
Communicator Type
Account Number
Dynamic Priority
Dynamic Delay
Report All
Report Alarms
Report Troubles
Report Open/Close
Report Tests
4. Select the "Save" button when programming is complete.



All four digits of the Central Station Account numbers must be entered. For ten-digit format, all ten digits must be entered. Refer to the Lynx Plus Series Installation and Setup Guide for additional information regarding these programming options.

8. Register the Communications Module

The Communications Module can be registered either via the Alarmnet Direct Website, by Phone or through the LYNX Touch Diagnostics. For additional information on the first two methods refer to the LYNX Touch Installation and Setup Guide P/N 800-06834 or higher.

Register through LYNX Touch Diagnostics

To Register the Communications Module, you must enter Programming Mode.

1. Select the "Comm./Diagnostics" button.
2. Select the "Setup Communications" button.
3. Select the "Register Device" button. The registration message is sent and the unit waits for the acknowledgement. (Refer to the LYNX Touch Installation and Setup Guide P/N 800-06834 or higher for additional information)

9. Program User Functions

To perform these functions, you must enter the Master User Programming mode.

Add Users

1. Select the "Users" button.
2. Select the "Add New" button.
3. Enter a User Name.
4. Enter a 4-digit User Code.
5. Select "Done".

Change the Master User Code

1. Select the "Users" button.
2. Select the "Master" button.
3. Select the "Edit" button.
4. Enter a new 4-digit User Code.
5. Select "Done".

Change/Edit Users or User Codes

1. Select the "Users" button.
2. Select the applicable "User" button.
3. Select the "Edit" button.
4. Revise the User name, if applicable, then select the "Done" button.
5. Enter a new 4-digit User Code, if applicable, then select the "Done" button.

Delete User Codes

1. Select the "Users" button.
2. Select the applicable "User" button.
3. Select the "Delete" button.
4. Enter a new 4-digit User Code.
5. Select "Yes" when the confirmation screen appears.

10. Test the system

To perform this function, you must enter the Installer OR Master User Programming mode.

1. Select the "Test" button or icon.
2. Select the "Walk Test" button or icon.
3. Open each protected door and listen for three beeps from the keypad, followed by the zone's Voice Descriptor. Identification of each faulted protection point should appear on the display, and clear when the door is closed.
4. Walk in front of the motion sensor and listen for three beeps and the zone's voice descriptor.
5. When testing is complete, enter an OFF sequence.
6. Press each key on the key fob to confirm it performs its assigned function.

Note: Refer to the Lynx Touch Series User Guide P/N 800-06894 or higher for additional information.